

RHOTEN, CHRISTOPHER D.^{1*}, and JEFFREY L. CARLSON², ¹Western Sugar Cooperative, 2100 East Overland Drive, Scottsbluff, NE 69361, and ²Minn-Dak Farmers Cooperative, 7525 Red River Road, Wahpeton, ND 58075-9698. **A systematic approach to optimization of the BMA K-2300 continuous centrifugal.**

ABSTRACT

The optimization of a continuous centrifugal station is factory specific and related directly to the brix, purity, crystal quality and crystal content of the massecuite being processed through the station. The massecuite brix, purity, crystal size and crystal content influence the required basket speed, the position and number of sugar washing spray nozzles, the machine loading (capacity) and the volume of wash water required to produce the desired sugar color and green syrup purity. A systematic approach to the centrifugal optimization requires: (1st) the determination of the correct basket speed for required mother liquor separation and optimization of machine loading, (2nd) the determination of the correct number of and best position for the location of sugar washing spray nozzles and (3rd) the determination of the correct wash water flow rate to achieve the required sugar produced color and green syrup purity. The correct optimization of the identified operating parameters will generally lead to increased machine capacity, reduced wash water consumption and reduced sugar color with minimal increase in green syrup purity.

PLEASE SEE SLIDES THAT FOLLOW.

A systematic approach to optimization of the BMA K-2300 continuous centrifugal.

Christopher D. Rhoten
Jeffrey L. Carlson, Ph.D.

Objectives for Operation of Continuous High-Raw Centrifugal

- High throughput
- High sugar purity
- Low sugar color
- Low green syrup purity
- Low water use
- Low maintenance (high uptime)
- Long machine lifetime

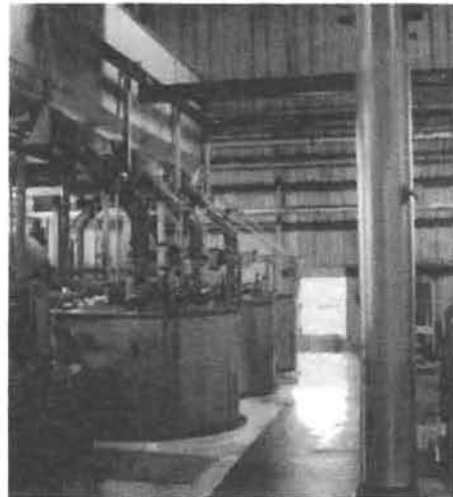

BMA K2300 Continuous Centrifugal

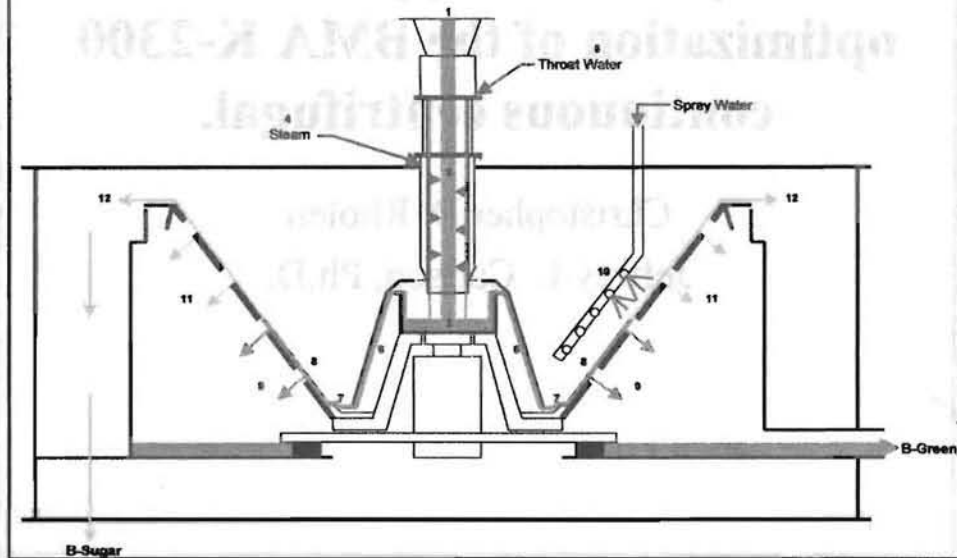

Operating Parameters



- Control Parameters
 - Mass flow
 - Steam flow
 - Throat water flow
 - Spray water flow
- Performance Monitors/Drivers
 - B-mass tank levels
 - B-green tank levels
 - Sugar color
 - Green syrup quality

Engineering Parameters

- Basket type
- Screen type
- Basket speed
- Spray nozzle location
- Spray water quality
 - Temperature, pressure and consistency
- Mass delivery system



B-Massequite Properties Affects Centrifugal Operations

- B-mass
 - Flow characteristics
 - Viscosity
 - Crystal content
 - Crystal quality
- Variability of B-Mass
 - Varies with Beets
 - Changes optimal engineering and operation parameters

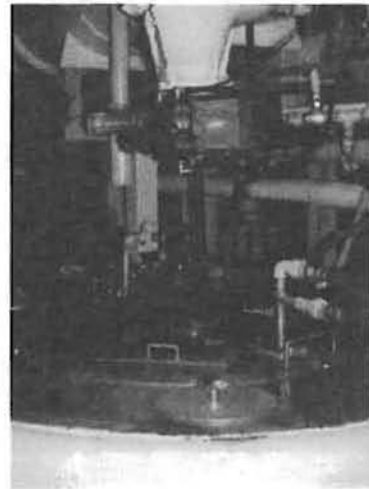

Machine Optimization (An Iterative Process)

- Select a starting point for a given massequite
 - basket speed
 - spray selection
 - spray water volume
 - machine load
- Vary parameters one-by-one, approaching the optimal conditions
- Repeat for different mass conditions with best guess starting point

Sugar Samples Must Be Representative

Original Sampler



Minn-Dak Sampler



Sampling Procedure Necessary

Continuous Centrifugal Sampling Procedure
Current Operation of Sampling Device

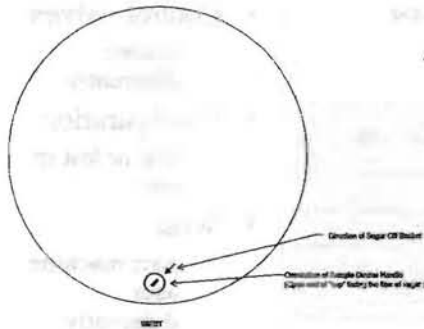

- Insert Sampling Device.
 - (10-15 seconds).
- Remove Excess from Outside of Cup.
- Scrape Entire Contents into Sample Container.
- Blend Sample.
- Clean Sampler Between Sample Type.

Load Optimized for Massequite

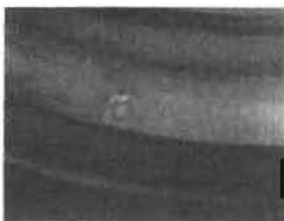

- Load Measurement
 - Amps
- Indicators
 - Sugar Quality
 - Syrup Quality
 - Visual

Variability between Machines Requires Researching

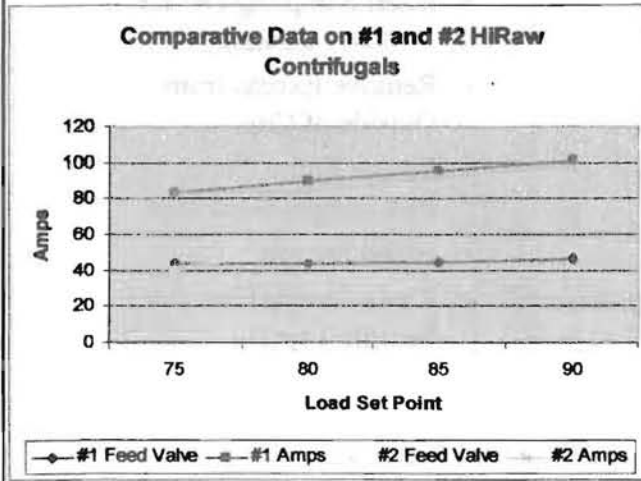

- Control valves
 - operate differently
- Configuration
 - first or last in line
- Wear
 - each machine ages differently

Basket Speed

- Changing Speed
 - Sheaves
 - VFD
- Optimal mother liquor removal
 - highest loading
 - lowest water use
 - lowest sugar color
 - lowest green purity

Optimized Basket Speed

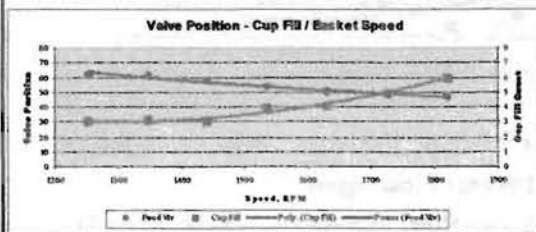
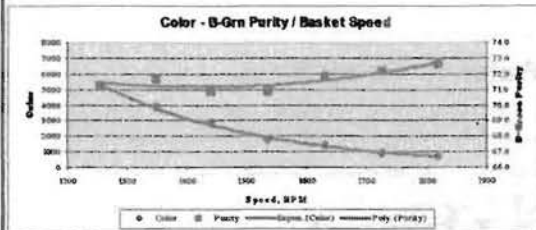

- **Optimized**

- 1585 rpm
- massequite conditions at MinnDak.
- loading of the machines should always be in the 75-95% range.
- For most operating conditions the machines should be operated at 90% of full motor load.

Spray Water Location

- **Throat Water**

- Add Only Enough to Lubricate Throat and Reduce Syrup Viscosity.
- Helps Prevent Massequite Back-up.
- Sticky, Hard to Separate Syrups may Require Additional Throat Water.
- Throat Water DOES NOT Wash Sugar.
- Excessive Throat Water Raises Green Purity.

- **Spray Water**

- Washes Most of the Remaining Green Syrup from the Crystals.
- Position of Spray Nozzles Effects:
 - Washing Efficiency - Color.
 - Green Purity

Water Addition Location

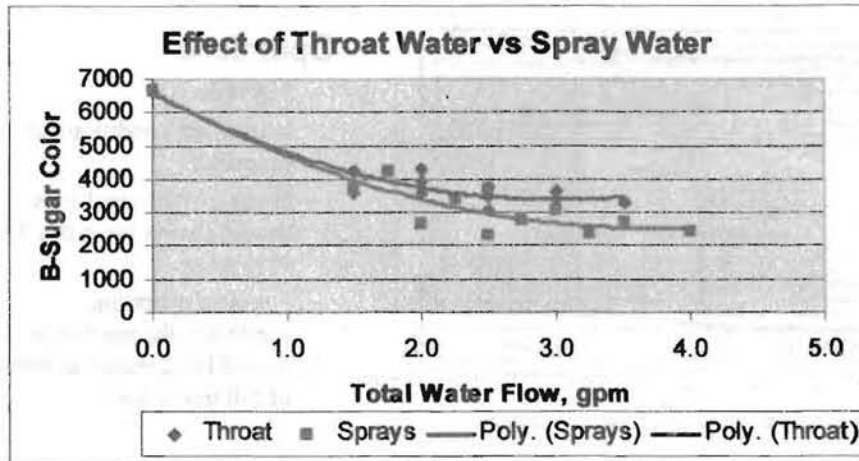

Affect of Spray Nozzle Position on B-Sugar Color

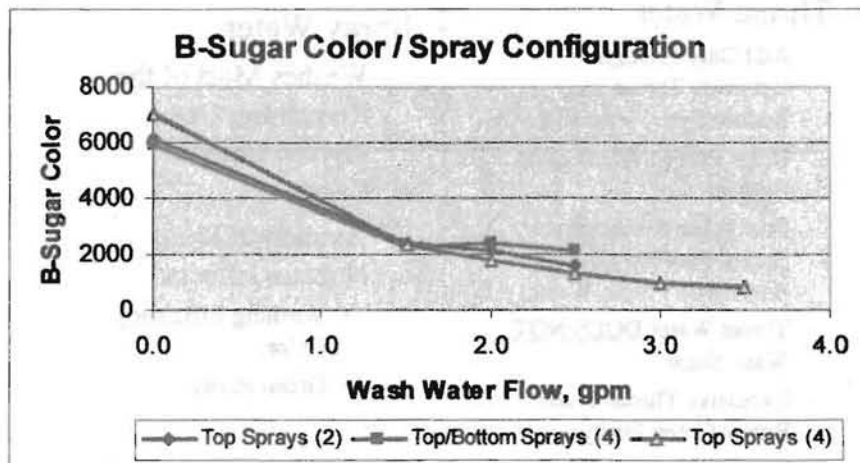

Affect of Spray Nozzle Position on Green Syrup Purity

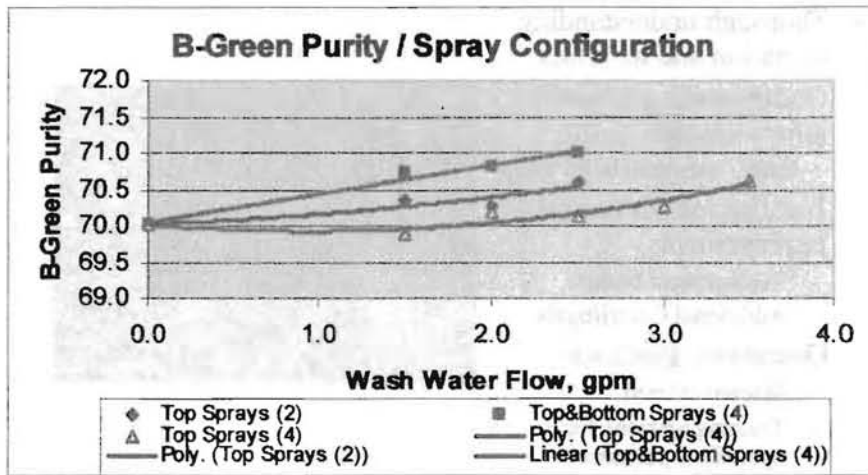

Relationship of Spray Water Volume and Sugar Color

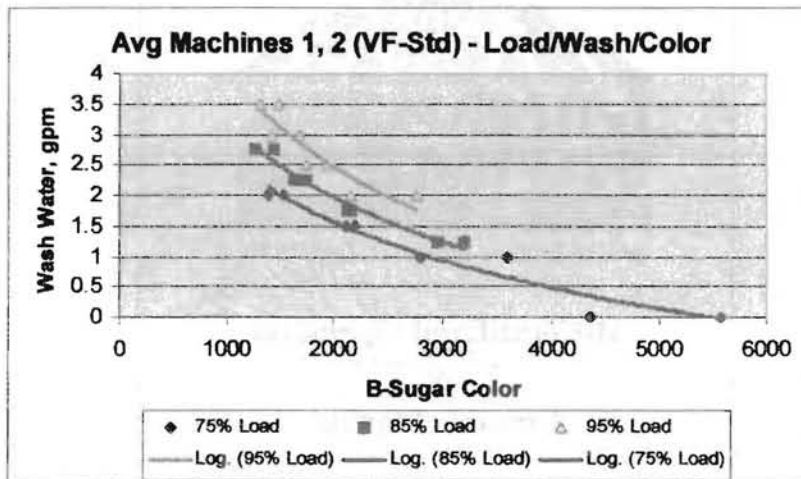

Results of Study

- Thorough understanding of station and its limits
- Understanding of needed improvements
 - many corrected to do study
- Justification for capital improvement
 - Replacement baskets
 - Additional Centrifugals
- Operations guidance
 - Manual created
 - Training sessions for operations personnel



B-Centrifugal Operation
&
Control Manual

Subjects

Introduction	4
Operating Theory	4
Operation and Control of the K-2300 B-Centrifugal	6
Machine Load Control	7
Steam Addition	8
Throat Water Addition	9
Spray Water Addition	10
Wash Water Supply System	12
B-Sugar Color Control	13
B-Green Purity Control	15
Routine Machine Maintenance	16
B-Sugar Sampling	17
Process Troubleshooting	18
High Color B-Sugar	18
Worn or Fouled Working Screens	19
Low Brix B-Massecurite	19
Wash Water Pressure Fluctuation	20
Operation and Control of the K-850 B-Centrifugal	21
Machine Load Control	22
Steam Addition	23
Throat Water Addition	23
Spray Water Addition	23